

REV.	DESCRIPTION	DATE
A		
B		05-2010

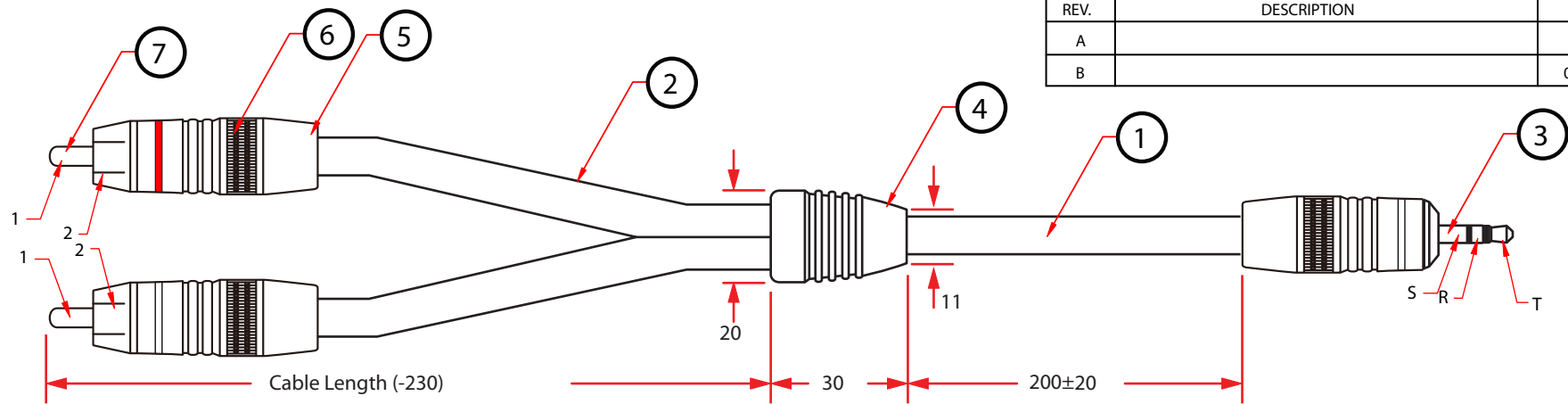

RCA / M

Cable Length (~230)

Pinout		
RCA / M / Red	3.5mm / M	RCA / M / White
1	T	1
2	R	2
	S	

3.5mm / M

RoHS

RCA Cable Specifications:

- 1 Conductor: OFC Copper (0.12mm*20)
- 2 Core Dielectric: Gas Injected Foam PE
- 3 Shield Braid: OFC Copper (0.12mm/16*4)
- 4 Black PVC Jacket
- 5 Mylar Aluminum Foil

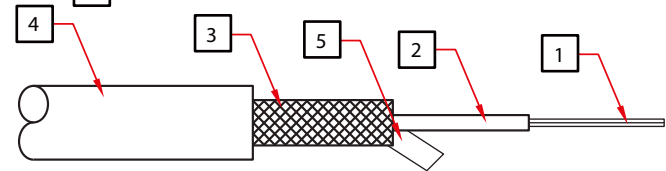

Stereo Cable Specifications:

- 1 Conductor: OFC Copper (0.12mm*20) * 2
- 2 Core Dielectric: Gas Injected Foam PE * 2
- 3 Shield Braid: OFC Copper (0.12mm/16*4)
- 4 Black PVC Jacket
- 5 Mylar Aluminum Foil

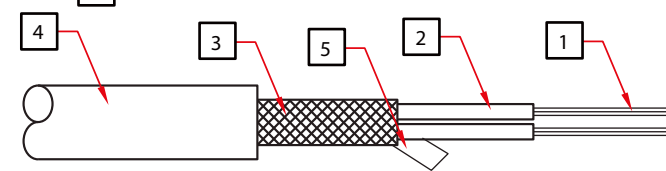

PART NO.	CABLE LENGTH
10A3-12106	6 ft
10A3-12112	12 ft
10A3-12125	25 ft
10A3-12135	35 ft
10A3-12150	50 ft
10A3-12175	75 ft
10A3-121HD	100 ft

7	RCA Male: Brass, Gold Plated
6	Sleeve, Black Rubber
5	Shell, Satin White Chrome
4	Bushing: Black PVC
3	3.5mm Stereo Male: Brass, Gold Plated
2	1C (0.12mm*20) + AL-Foil + Braid, Cable: 7.0mm, Black PVC (See Cable Spec for more details)
1	2C (0.12mm*20) + AL-Foil + Braid, Cable: 7.0mm, Black PVC (See Cable Spec for more details)
NO.	SPECIFICATIONS
	BOM LIST

ITEM NUMBER	10A3-121xx		DRAWER	LIBRA
TITLE	3.5mm Male to 2 x RCA Male, Premium Grade Audio Y Cable		CHECKED	
MATERIAL	SCALE		APPROVED	
REV.	B	UNIT	INCH	
DRAWING NO:				
 888-212-8295.com				

REV.	DESCRIPTION	DATE
A		
B		02-2006

ITEMS	CONDITIONS	SPECIFICATIONS
Appearance		No defects such as cracks, scratches or blemishes.
Insertion force withdrawal force	Measurement shall be made after inserting into it's mating plug or socket three times. RCA Plug.	5.88N(0.6Kgf) ~ 49.0N(5.0Kgf)
Tensile Strength	Between Cable & Connector 49.0N(5.0KGF), 1 Minute	No damage such as displacement or insulation damage, etc
Flexing Test	500G, +/-60 degrees, 1000 Turns 15~20 / Per Min Turns	No damage such as displacement or insulation damage, etc
Insulation Resistance	DC 250V 1 minute between conductors	100 M Ohm or more
Dielectric Strength	AC 250V Shall be applied for 1 minute with trip current 2mA between conductors	Without damage such as electric breakdown
ABS Non-migration	Temperature: 54 +/-1 C Time: 24 +/-1 H Weight: 500 +/-25 G	When visually inspected, any staining of the ABS area that was in contact with the test pieces shall hardly be recognized

Remark: 1. 75 Ohms Cable
2. Capacitance: 70PF/M Max

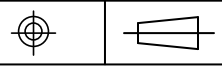
ITEM NUMBER	10A3-121xx		DRAWER	MPD
TITLE	3.5mm Male to 2 x RCA Male, Premium Grade Audio Y Cable		CHECKED	MAC
MATERIAL	SCALE		APPROVED	MAC
REV.	A	UNIT	INCH	
DRAWING NO:			